

# SIEMENS

Elektronisches Überlastrelais  
Solid-state overload relay  
Relais de surcharge électronique  
Relé electrónico de sobrecarga  
Relè elettronico di sovraccarica  
Elektroniska överlastrelä

## 3RB12

Kanchan Enterprises  
Ph.no.-2533 3226 / 4766  
Email id- e@kanchananand.com

Betriebsanleitung  
Instructions

Bestell-Nr./Order No.: 3ZX1012-0RB12-1AA1  
Ausgabe/Edition 01/2003

GWA 4NEB 631 2282-30a

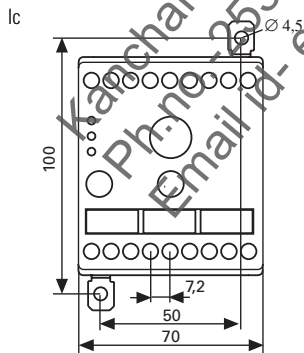
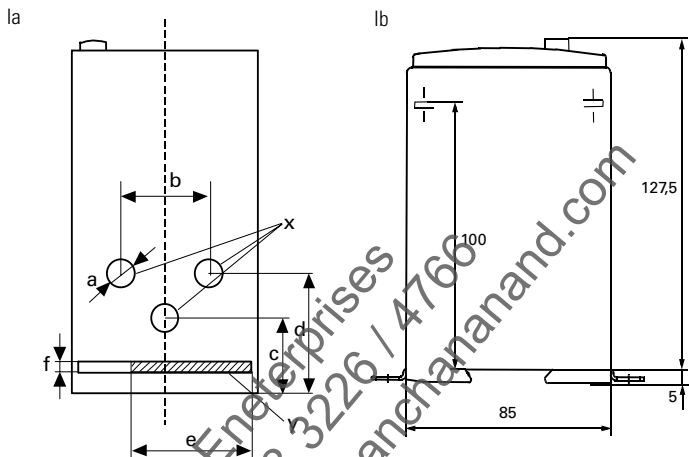

	3RB1246-1P 3RB1246-1Q	3RB1246-1E
a	10	15
b	34	29
c	29	24
d	46	47
e	48	---
f	4	---

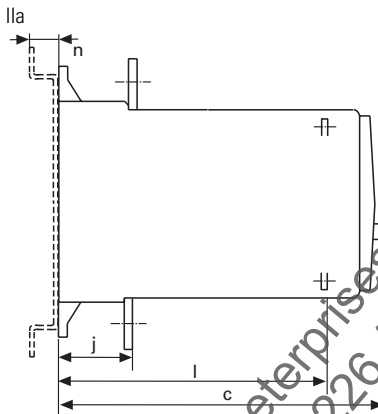

	3RB1253-0F	3RB1257-0K	3RB1262-0L
a	120	145	230
b	85	85	85
c	155	175	190
d	110	105	120
e	40	50	70
f	∅ 7	∅ 9	∅ 11
g	42	52	70
h	37	48	---
i	125	130	135
j	47	46	55
k	20	30	40
l	131	151	166
m	7,2	7,2	7,2
n	13	---	---
o	145	160	175

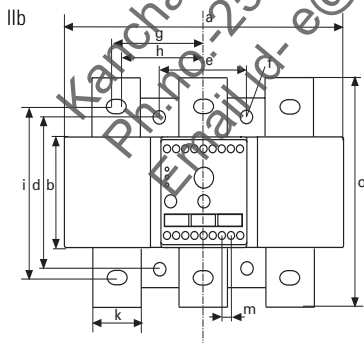

III

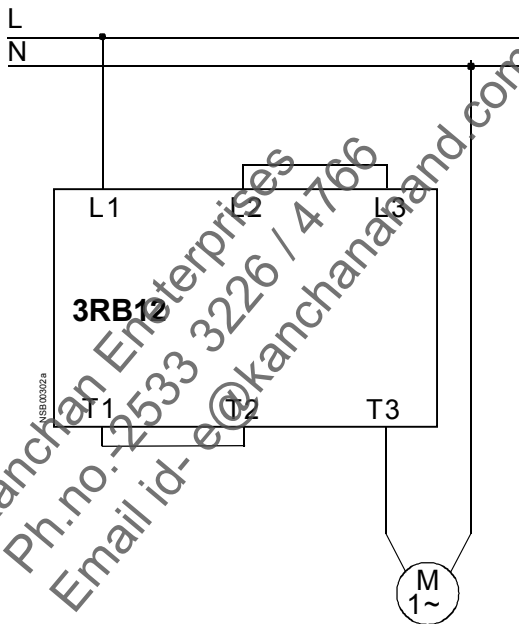

IV

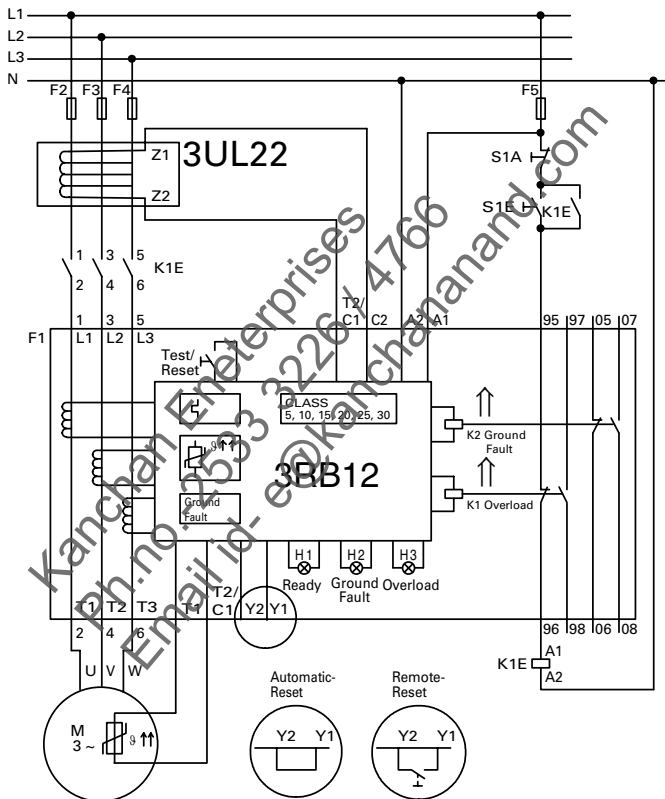

V  
3RB12...-...0  
3RB12...-...2

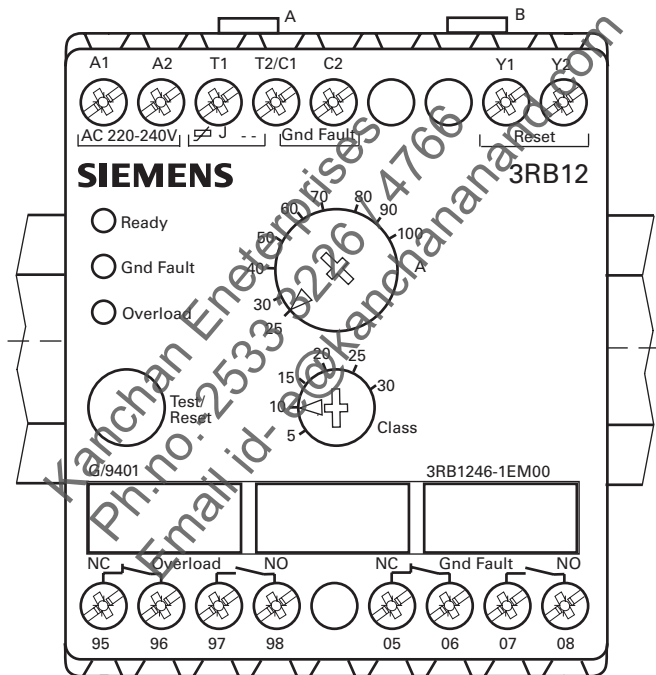

VI  
3RB12...-...1  
3RB12...-...3

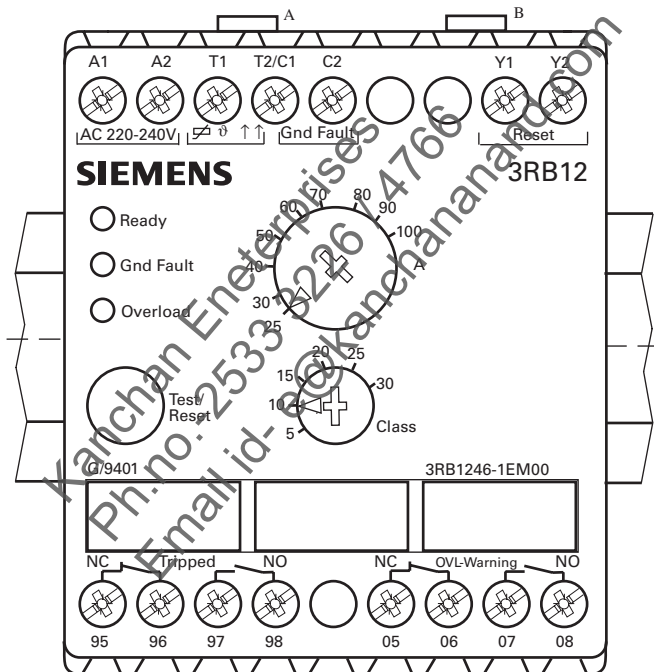

VII

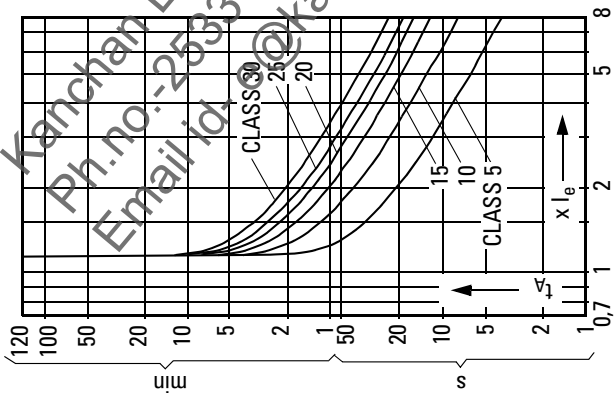

VIII

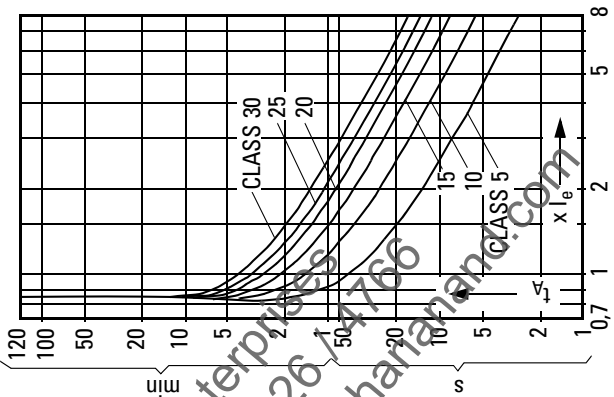





### Limited touch protection

Degree of protection in conformity with IEC 60529:  
IP 20 for devices 70 mm  
IP 00 for devices > 70 mm

Shock-proof in conformity with DIN VDE 0106, Part 100.

Installation and maintenance by technical personnel only. Follow the operating instruction!

	<b>WARNING</b>
	<b>HAZARDOUS VOLTAGE CAN CAUSE ELECTRICAL SHOCK AND BURNS. DISCONNECT POWER BEFORE PROCEEDING WITH ANY WORK ON THIS EQUIPMENT.</b>

## 1 Device description

The 3RB12 electronic overload relay protects electrical equipment, such as three-phase AC motors and transformers, with three different protection mechanisms.

### Overload protection

The 3RB12 compares the motor current actually flowing with the set current and evaluates the values in a microprocessor.

### Thermistor protection

PTC thermistors in the motor windings sense the motor temperature. If the thermistor responds, the relay trips.

### Earth-fault protection

Versions with internal earth-fault detection are suitable for service in three-wire systems.

Versions with earth-fault detection by means of an external summation current transformer are suitable for service in three-wire and four-wire systems.

## 2 Installation

For dimension drawings, see graphics section, Fig. I and II.

Mounting position: any

Mounting of 70 mm devices:

- Snap-on mounting on 35 mm mounting rail in conformity with EN 50 022 or
- screw mounting by means of inserted lugs as accessory (3RB1900-0B).

Mounting of the 120 mm, 145 mm und 230 mm devices:

- Crew mounting integrated in the casing.
- In addition for 120 mm size:  
Baseplate for snap-on fastening on 75 mm mounting rail (3UF1900-0J) available as accessory.

## 3 Connection

### 3.1 Main conductor connection

#### 3.1.1 Current range up to 100 A

- Rated motor currents from 1.25 A to 100 A:  
Insert the motor leads per phase through the openings (x) in the unit (see graphics section, Fig. Ia).
- Rated motor currents less than 1.25 A:  
Insert the motor leads per phase through the openings (x), take them back through the loop opening (y) and insert them again through the openings (x). You will produce two loops in this way (see graphics section, Fig. Ia).  
The following table lists the number of loops for the various rated motor currents.

Number of loops n	5	4	3	2
Rated motor current $I_N$ [A]	0.25 to 0.3	0.31 to 0.41	0.42 to 0.62	0.63 to 1.24

The device setting current  $I_e$  calculated according to:  
 $I_e = n \times I_N$

**Example**

$I_N = 0.5$  A;  $n = 3$ ;  $I_e = 1.5$  A

**Protection of single-phase motors**

If single-phase AC motors are to be protected by the 3RB12 solid state overload relay, phase L must be looped through the device. The main circuits must be connected as shown in Fig. III.

**Note**

This is only possible if the device has no internal earth fault detection:

3RB12 46- ...0., -...1.

3RB12 53- ...0., -...1.

3RB12 57- ...0., -...1.

3RB12 62- ...0., -...1.

### 3.1.2 Current range 50 A to 820 A

Busbar connection: see graphics section, Fig. II

	Finely stranded conductor with cable lug [mm <sup>2</sup> ]	Stranded conductor with cable lug [mm <sup>2</sup> ]	Connection screws	Tightening torque [Nm/lb.in]	Tag termination [mm x mm]
3RB1253	35 to 95	50 to 120	M8	10 to 14 / 89 to 24	20 x 4
3RB1257	50 to 240	70 to 240	M10	14 to 24 / 124 to 210	30 x 6
3RB1262	50 to 240	185 to 240	M 10 (Connection to contactor 3TF68)	14 to 24 / 124 to 210	40 x 8
			M 12 (Connection to contactor 3TF68)	20 to 35 / 177 to 310	

### 3.2 Auxiliary conductor connection

Solid [mm <sup>2</sup> ]	Finely stranded with/without end sleeve [mm <sup>2</sup> ]	AWG	Connecting screws [mm]	Tightening torque [Nm/lb.in]
1x(0.5 to 4) 2x(0.5 to 2.5)	1x(0.5 to 2.5) 2x(0.5 to 1.5)	20 to 14	0.8x4...5.5 Pozidriv 2	0.8 to 1.2/ 7 to 11

### Thermistor sensor

A link (A) is in place when the device is delivered. This link must be removed when the sensor is connected (see illustration in Fig. V and VI).

### 3.3 Connection scheme

See graphics section of Fig. IV for circuit diagram, showing Automatic resets and remote resets.  
Facility for connecting summation current transformer 3UL22 for external earth fault monitoring.

## 4 Operation

### 4.1 Setting the current

- Use the current setting range knob to set the appropriate current.

### 4.2 Adjust tripping classes

---

#### Note

The motor, leads and contactor must be rated for the appropriate class. Class 10 as delivered.

---

- Check the class setting before initial start-up and correct it if necessary!
- Use the class changeover switch to select the appropriate tripping characteristic (see graphic section of Fig. VIII).

In the event of unsymmetry > 40 % (as per NEMA) and phase failure, tripping occurs as shown in Fig. VIII. The characteristics apply to a cold start. For starting under full load, the tripping times  $t_A$  are reduced.

---

#### Note

With the aid of the sealable cover plate 3RB1900-0A, the current range setting knob and the class changeover switch can be protected from tampering. To do this, simply snap on the cover plate instead of the middle nameplate.

---

### 4.3 Device statuses

Type	3RB12..-.....	3RB12..-...0. 3RB12..-...2.	3RB12..-...1. 3RB12..-...3.
Status	Operating indic.	Auxiliary switch	
<b>Device ready for operation</b> no overload not tripped	Ready LED: Green steady light	95/96, 05/06 closed 97/98, 07/08 open	
Changed auxiliary switch statuses			
Overload alarm	Overload LED: Red flashing light*		05/06 open 07/08 closed
Overload trip/ thermistor trip	Overload LED: Red steady light	95/96 open 97/98 closed	
Earth fault alarm	Gnd. Fault LED: Red Steady light	05/06 open 07/08 closed	95/96 open 97/98 closed

\* The overload LED flashes when the limit tripping current is reached and indicates that tripping is imminent.

Status	Mode indicator	Auxiliary switch
<b>Device not ready for operation</b> control voltage failure	Ready LED: Dark	Monostable version of device: 95/96, 05/06 open 97/98, 07/08 closed Bistable version of device: Switching statuses are retained

Five minutes after overload tripping, the 3RB12 can be reset to operating mode.

#### 4.4 Test

Statuses after the Test/Reset button has been pressed:

Test button	Status	Without main current		With main current*	
		O.k.	Faulty	O.k.	Faulty
Press for <b>up to 2 s</b>	LED Ready	●	●	●	●
	LED Gen. Fault	●	●	●	●
	LED Overload	●	●	●	●
	Status of auxiliary switching elements	unchanged			
Press for <b>after 2 s</b>	LED Ready	●	○	●	○
	LED Gen. Fault	●	●	⊗	●
	LED Overload	●	●	⊗	●
	Status of auxiliary switching elements	unchanged	Reset**	unchanged	Reset**
Press for <b>&gt; 5 s</b>	LED Ready	●	○	●	○
	LED Gen. Fault	●	●	●	●
	LED Overload	●	●	●	●
	Status of auxiliary switching elements	Reset			

● LED lights up   ● LED flashes   ⊗ LED flickers   ○ LED dark

\* Unless current is detected in all three phases, the device behaves as listed in the "Without main circuit current" column.

\*\* Status of auxiliary switching elements "Reset":  
95/96, 05/06 open, 97/98, 07/08 closed.

**Note**

The test with a test time of less than 5 s can be performed during operation. In a fault-free state the outputs remain unchanged.

**4.5 Reset**

When the 3RB12 has tripped because of	Reset the overload relay after the following times by		
	briefly pressing the test / reset button	Remote reset (briefly press button at Y1-Y2)	automatic-reset (bridge** Y1-Y2)
Test	immediately		
Overload*	after 5 min		
Thermistor*	If the temperature has reached 5 K below the response temperature		
Earth fault	immediately	not effective	

\* If thermistor and overload has tripped simultaneously, the longer reset phase applies

\*\* Bridge (B) is fixed to Y1 as delivered (see graphics section of Fig. V and VI).

**Reset function with free trip**

The protection functions are not impeded by holding down the test/reset button.



## 5 Technical data

<b>Specifications</b>	DIN VDE 0660 Part 102 / IEC 60947-4-1, DIN VDE 0660 Part 200 / IEC 60947-5-1, UL 508, CSA C 22.2	
<b>EMC</b>	Pulse packets (burst), IEC 61000-4-4	2 kV
	Discharge of static electricity, IEC 61000-4-2	8 kV
	Radiated high-frequency fields, IEC 61000-4-3	3 V/m
	Surge voltage, IEC 61000-4-5	2 kV
<b>Weight</b>	70 mm: 0.6 kg	145 mm: 1.9 kg
	120 mm: 1.0 kg	230 mm: 3.2 kg
<b>Rated control supply voltage</b>	Working range: AC 0.85 to 1.1 x $U_n$ ; 2 VA 24 V DC: 0.85 to 1.2 x $U_n$ (DIN 19 240); 2W	
<b>Main circuit</b>	Frequency	50/60 Hz
	Rated insulation voltage $U_i$	1000 V
	3RB1246	690 V
	Permissible ambient temperature	-25 to +70 °C
	Storage:	-40 to +80 °C
	Tripping limit values with three-pole symmetrical overload:	
	Tripping current	110...120% x $I_e$
	Tripping time	< 20 min
<b>Auxiliary circuit</b>	Contacts	2 x (1 NO and 1 NC)
	Electrical isolation of the auxiliary switch (potential-free)	
IEC:	Rated insulation voltage $U_i$	300 V
	Switching capacity:	
	AC-15:	6A/24V; 6A/120V; 3A/230V
	DC-13:	2A/24V; 0.55A/60V; 0.25A/125V
UL/CSA:	B300, R300	

**Short-circuit protection**

**Main circuit**

Short-circuit protection with fuses for motor feeders with short-circuit currents up to 50 kA at 690 V, 50/60 Hz (see data given in catalog)

**Control circuit**

Fuse links, duty class	gL/gG 6 A quick-acting 10 A
Protective circuit-breaker	1.6 A C characteristic

**Thermistor protection**

Thermistor sensor in the motor is connected to terminals T1/T2

Total cold resistance  $R_{cold}$  1.5 k $\Omega$

Measuring circuit loading  $\leq 5$  mW

(at  $R_{cold} = 1.5$  k $\Omega$ )

Voltage at sensor circuit  $\leq 2$  V (at  $R_{cold} = 1.5$  k $\Omega$ )

Response value 2.7 to 3.1 k $\Omega$

Return value 1.5 to 1.65 k $\Omega$

**Earth fault protection**

The following information is based on sinusoidal fault currents of 50/60 Hz:

**external**

Summation current transformers 3UL220.-A are connected to terminal C1/C2. The pick-up delay is 200 ms  $\leq t \leq 500$  ms.

**internal**

With a motor current between 0.3 and 2 times the set current, the device trips in the event of an earth-fault current of 30% of the set current.

With a motor current between 2 and 8 times the set current, the device trips in the event of an earth-fault current of 15% of the set current.

The pick-up delay is 0.5 to 1 seconds.

Kanchanar Energypriests 25333226 / 4766  
Ph.no: 25333226 / 4766  
Email: id-@kanchanarand.com



### Protection partielle contre les contacts directs

Degré de protection selon CEI 60529:

IP 20 pour relais de largeur 70 mm

IP 00 pour relais de largeur > 70 mm

Protégé contre l'accès avec un doigt selon

DIN VDE 0106, partie 100

Mise en service et maintenance uniquement par des personnes qualifiées. Respectez les instructions de service!

	<b>Attention !</b>
	<b>Tension dangereuse !</b> <b>Risque d'électrocution et de brûlure.</b> <b>Isoler cet appareil du réseau avant d'y intervenir pour travaux</b>

## 1 Description de l'appareil

Le relais électronique de surcharge 3RB12 dispose de différents mécanismes de protection pour les matériels électriques tels que moteurs triphasés et transformateurs.

### Protection contre les surcharges

Le 3RB12 compare le courant momentané du moteur avec le courant de réglage du relais et traite les valeurs dans un microprocesseur.

### Protection des moteurs par thermistance

Les sondes à thermistance CTP placées dans les enroulements du moteur assurent la mesure de la température de ce dernier. Lors du dépassement d'un seuil, le relais provoque le déclenchement.

### Protection contre les défauts à la terre

Appareils avec reconnaissance interne de défauts à la terre pour réseaux 3 conducteurs.

Appareils avec reconnaissance de défauts à la terre par transformateur sommateur externe pour réseaux à 3 ou 4 conducteurs.